

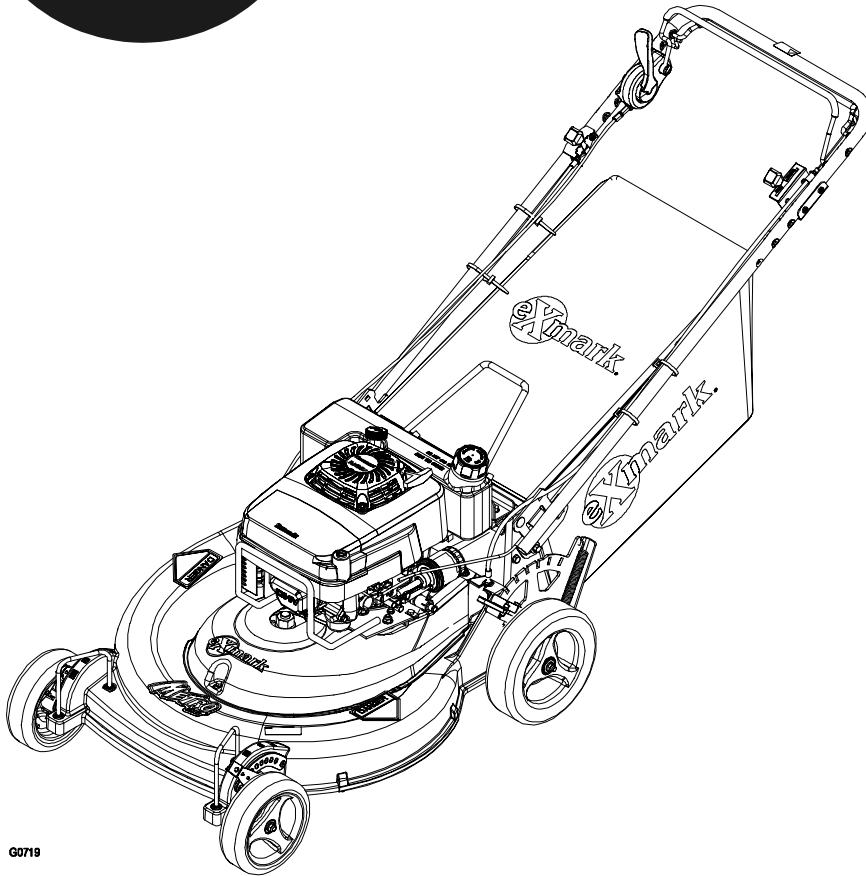

For Serial Nos.
561,194 & Higher
and
600,000 & Higher



G0719

METRO[®] 26

OPERATOR'S MANUAL

CONGRATULATIONS on the purchase of your new Exmark mower. This product has been carefully designed and manufactured to give you a maximum amount of dependability and years of trouble-free operation. If additional information is needed, or should you require trained mechanic service, contact your authorized Exmark equipment dealer or distributor. If you need to order replacement parts from your dealer, always give the model number and serial number of your mower as well as the part number, description and quantity of the part needed.

The Serial No. plate is located on the right hand side of the mower deck near the rear of the machine. For ease of ordering and reference, we suggest that you record the information requested in the following identification table.



Place Model No. and Serial No. Label Here (Included in Literature Pack) or Fill in Below
Model No. _____
Serial No. _____

Engine Model No. and Spec. No. (Code) _____

Engine Serial No. (E/No) _____

Date Purchased _____

 WARNING 	
POTENTIAL HAZARD	
◆ This product is a piece of power equipment.	
WHAT CAN HAPPEN	
◆ Failure to follow safe operating practices can result in serious operator injury or even death.	
HOW TO AVOID THE HAZARD	
◆ Keep all shields, guards, and safety devices (especially the grass discharge system) in place and in proper working condition.	
◆ Stop engine, wait for all moving parts to stop and engage parking brake. Remove spark plug wire(s) or remove key before adjusting, servicing, or performing maintenance.	
◆ If mower deck becomes clogged, stop engine, wait for all moving parts to stop and engage parking brake. Remove spark plug wire(s) or remove key before cleaning blockage.	
◆ Keep hands, feet, and clothing away from power driven parts.	
◆ Keep off mower unless seat platform is provided.	
◆ Keep others off mower.	

 WARNING 	
POTENTIAL HAZARD	
◆ Gasoline is harmful or fatal if swallowed. Long-term exposure to vapors has caused cancer in laboratory animals.	
WHAT CAN HAPPEN	
◆ Failure to use caution may cause serious injury or illness.	
HOW TO AVOID THE HAZARD	
◆ Avoid prolonged breathing of vapors.	
◆ Keep face away from nozzle and gas tank/container opening.	
◆ Keep away from eyes and skin.	
◆ Never siphon by mouth.	

IMPORTANT

When the mower is used or operated on any California forest, brush or grass covered land, a working spark arrester must be attached to the muffler. If not, the operator is violating state law, Section 4442 Public Resource Code. To acquire a spark arrester for your unit, see your Engine Service Dealer.

This spark ignition system complies with Canadian ICES-002
 Ce système d'allumage par étincelle de véhicule est conforme à la norme NMB-002 du Canada

The enclosed Engine Owner's Manual is supplied for information regarding The U.S. Environmental Protection Agency (EPA) and the California Emission Control Regulation of emission systems, maintenance and warranty.

Keep this engine Owner's Manual with your unit. Should this engine Owner's Manual become damaged or illegible, replace immediately. Replacements may be ordered through the engine manufacturer.

Exmark reserves the right to make changes or add improvements to its products at any time without incurring any obligation to make such changes to products manufactured previously. Exmark, or its distributors and dealers, accept no responsibility for variations which may be evident in the actual specifications of its products and the statements and descriptions contained in this publication.

EXMARK PARTS PLUS® PROGRAM

EFFECTIVE DATE: September 1, 1995

Program

If your Exmark dealer does not have the Exmark part in stock, Exmark will get the parts to the dealer the next business day or the part will be FREE* Guaranteed!!

How the Program Works

1. If dealer does not have part in stock for a "down" unit at the time of request by customer, the dealer contacts his distributor by 1:00 p.m., local time, and requests Exmark Parts Plus® shipment of six (6) line items or less.
2. Distributor ships part(s) to dealer or customer, as requested by dealer, same day, overnight UPS. Distributor bills dealer for part and freight charges where applicable.
3. If distributor does not have the part(s) in stock to satisfy Exmark Parts Plus® order, he contacts Exmark by 3:00 p.m., central time, with an Exmark Parts Plus® order of six (6) line items or less.
4. If order is received by 3:00 p.m. central time, Exmark ships part(s) direct to dealer or customer, as requested by distributor, same day, overnight UPS, Exmark bills the distributor for parts and shipping charges, where applicable.
5. The customer pays for the part and freight if it is shipped under the Exmark Parts Plus® and if it arrives in accordance to the program.
6. Who pays for the part and freight if it fails to arrive overnight in accordance to the program?
 - A. Under any circumstance the customer does not pay.
 - B. If the part does not arrive overnight due to:
 1. The dealer not submitting the Exmark Parts Plus® order to his Exmark distributor by 1:00 p.m., the dealer pays for the part and freight.
 2. The Distributor being unable to ship the part the same day or not submitting the Exmark Parts Plus® order to Exmark by 3:00 p.m., central time, the Distributor pays for the part and freight.
 3. Exmark being unable to ship the part and the Exmark parts order is received by 3:00 p.m., central time, Exmark pays for the part and freight.
 4. If the part does not arrive overnight due to the shipper (UPS), the shipper pays for the freight and Exmark pays for the part.

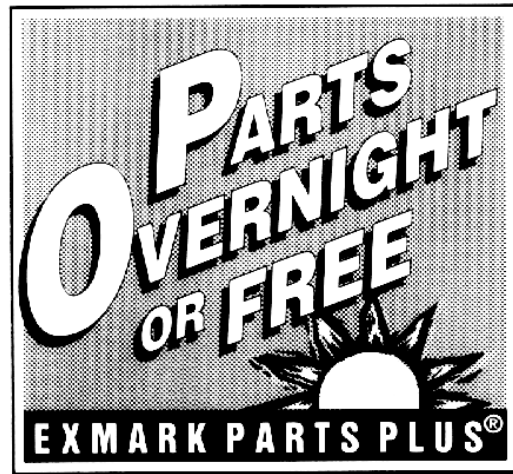

The following restrictions apply -- The Exmark Parts Plus® Program is available only through participating Exmark Dealers and applies only to orders submitted on this program Monday through Thursday. Parts Plus service is available only in the 48 contiguous United States. UPS has initiated a Saturday delivery program to many areas of the continental United States and can be requested for an overnight shipment on Friday to be delivered Saturday. The next day air charge, plus the Saturday delivery fee will be the responsibility of the purchaser. Exmark Mfg. will assume no responsibility for Saturday delivery shipments. To qualify, all Exmark Parts Plus® orders must be received by Exmark by 3:00 p.m., central time. Orders must be six (6) line items or less. Exclusions from the Exmark Parts Plus® Program are: Any wholegood or accessory in its entirety, engines and engine replacement parts, 5-speed Peerless transmissions and 5-speed transaxles, hydraulic or hydrostatic wheel motors, cutter decks and engine decks or any item exceeding United Parcel Service size and weight restrictions.

Due to UPS restrictions, aerosol spray paint is considered a hazardous material and cannot be shipped via UPS next day or Second Day Air.

Exmark Manufacturing stocks a limited supply of parts for transaxles, pumps and wheel motors. These parts can be ordered for Next Day Air shipment but will not be guaranteed per the Parts Plus Program.

CONGRATULATIONS on the purchase of your Exmark Mower. This product has been carefully designed and manufactured to give you a maximum amount of dependability and years of trouble-free operation.

OPERATOR'S MANUAL

This manual contains operating, maintenance, adjustment, and safety instructions for your Exmark mower.

BEFORE OPERATING YOUR MOWER, CAREFULLY READ THIS MANUAL IN ITS ENTIRETY.

By following the operating, maintenance, and safety instructions, you will prolong the life of your mower, maintain its maximum efficiency, and promote safe operation.

If additional information is needed, or should you require trained mechanic service, contact your authorized Exmark equipment dealer or distributor.

All Exmark equipment dealers and distributors are kept informed of the latest methods of servicing and are equipped to provide prompt and efficient service in the field or at their service stations. They carry ample stock of service parts or can secure them promptly for you from the factory.

All Exmark parts are thoroughly tested and inspected before leaving the factory; however, attention is required on your part if you are to obtain the fullest measure of satisfaction and performance.

TABLE OF CONTENTS

	PAGE
1. SAFETY	
1.1 Safety Alert Symbol	1
1.2 Training.....	1
1.3 Preparation.....	1-5
1.4 Operation.....	5-7
1.5 Maintenance & Storage	7
1.6 Safety Signs	8
2. SPECIFICATIONS	
2.1 Model Numbers	9
2.2 Engine	9
2.3 Fuel System.....	9
2.4 Transmission	9
2.5 Deck	9
2.6 Dimensions.....	9
3. OPERATION INSTRUCTIONS	
3.1 Controls	9-10
3.2 Pre-Start	10-11
3.3 Operating Instructions	11-18
4. MAINTENANCE	
4.1 Checking the Engine Oil Level	19
4.2 Checking the Blade Brake Clutch.....	19
4.3 Cleaning the Underside of the Lawn Mower Housing	19-20
4.4 Cleaning the Discharge Tunnel	20
4.5 Servicing the Air Filter	21-22
4.6 Maintaining the Blade	22-24
4.7 Cleaning the Under the Cover	24
4.8 Emptying the Fuel Tank and Cleaning the Fuel Filter	24-25
4.9 Lubricating the Pivot Arms	25
4.10 Adjusting the Self-Propelled Drive.....	25
4.11 Servicing the Spark Plug	26
4.12 Changing the Engine Oil.....	26
4.13 Changing the Oil Filter	27-28
4.14 Lubricating the Gear Case	28
4.15 Adjusting the Blade Brake Cable.....	28-29
4.16 Servicing the Wheels.....	29
5. STORAGE	
5.1 Preparing the Fuel System	29-30
5.2 Preparing the Engine.....	30
5.3 General Storage Information	30
5.4 Removing the Lawn Mower from Storage	31
6. ACCESSORIES	31
7. TROUBLESHOOTING	31-32
8. WARRANTY	33
9. EMISSION CONTROL WARRANTY STATEMENT	34

1. SAFETY

This lawn mower meets or exceeds the CPSC blade safety requirements for walk-behind rotary mowers and the B71.4 specifications of the American National Standards Institute in effect at the time of production.

Exmark designed and tested this lawn mower to offer reasonably safe service; however, **failure to comply with the following instructions may result in personal injury.**

1.1 SAFETY ALERT SYMBOL

This SAFETY ALERT SYMBOL  is used both in this manual and on the machine to identify important safety messages which must be followed to avoid accidents. This symbol means:

**ATTENTION! BECOME ALERT!
YOUR SAFETY IS INVOLVED!**

The safety alert symbol appears above information which alerts you to unsafe actions or situations and will be followed by the word **DANGER**, **WARNING**, or **CAUTION**.

DANGER: White lettering/Red background. Indicates an imminently hazardous situation which, if not avoided, **WILL** result in death or serious injury.

WARNING: Black lettering/Orange background. Indicates a potentially hazardous situation which, if not avoided, **COULD** result in death or serious injury.



CAUTION: Black lettering/Yellow background. Indicates a potentially hazardous situation which, if not avoided, **MAY** result in minor or moderate injury.

1.2 TRAINING



- 1.2.1 Regard the Exmark mower as a piece of power equipment and teach this regard to all who operate this unit.
- 1.2.2 Read the instructions carefully. Familiarize yourself with the controls and the proper use of the equipment. If the operator(s) or mechanic(s) can not read English it is the owner's responsibility to explain this material to them.
- 1.2.3 Do not allow operation of this machine by untrained personnel. Never allow children, teenagers, or people unfamiliar with these instructions to use the mower. Local regulations may restrict the age of the operator.
- 1.2.4 Avoid mowing while people, especially children, or pets, are nearby. Keep in mind that the operator or user is responsible for accidents or hazards occurring to other people or their property.

1.3 PREPARATION

- 1.3.1 Evaluate the terrain to determine what accessories and attachments are needed to properly and safely perform the job. Only use accessories and attachments approved by Exmark.
- 1.3.2 The use of personal protective equipment, such as (but not limited to) protection for the eyes, ears, feet, and head is recommended.

 CAUTION 	
POTENTIAL HAZARD	
<ul style="list-style-type: none"> ◆ This machine produces sound levels in excess of 85 dBA at the operator's ear when in operation. 	
WHAT CAN HAPPEN	
<ul style="list-style-type: none"> ◆ Exposure to sound levels of 85 dBA or above for extended periods of time can cause hearing loss. 	
HOW TO AVOID THE HAZARD	
<ul style="list-style-type: none"> ◆ Wear hearing protection when operating this machine. 	

- 1.3.3 While mowing, always wear substantial footwear and long trousers. Do not operate equipment when barefoot or when wearing open sandals.
- 1.3.4 Thoroughly inspect the area where the equipment is to be used and remove all stones, sticks, wires, bones, and other foreign objects which may damage the equipment or cause personal injury to the operator or bystanders.

 WARNING 	
POTENTIAL HAZARD	
<ul style="list-style-type: none"> ◆ Engine exhaust contains carbon monoxide, which is an odorless deadly poison. 	
WHAT CAN HAPPEN	
<ul style="list-style-type: none"> ◆ Carbon monoxide can kill you. 	
HOW TO AVOID THE HAZARD	
<ul style="list-style-type: none"> ◆ Do not run engine indoors or in a small confined area where dangerous carbon monoxide fumes can collect. 	



DANGER



POTENTIAL HAZARD

- ◆ In certain conditions gasoline is extremely flammable and highly explosive.

WHAT CAN HAPPEN

- ◆ A fire or explosion from gasoline can burn you, others, and cause property damage.

HOW TO AVOID THE HAZARD

- ◆ *DO NOT* smoke while refueling, and stay away from an open flame or where gasoline fumes may be ignited by spark.
- ◆ Refuel only outdoors.
- ◆ Store gasoline in an approved container and keep it out of the reach of children.
- ◆ Add fuel before starting the engine. *Never* remove the cap of the fuel tank or add fuel when engine is running or when the engine is hot.
- ◆ Never fill the fuel tank so that the gasoline level rises above a level that is 1/2" (1.3 cm) below the bottom of the filler neck to allow for gasoline expansion and prevent fuel spillage.
- ◆ If fuel is spilled, *DO NOT* attempt to start the engine. Move away from the area of the spill and avoid creating any source of ignition until fuel vapors have dissipated.
- ◆ Do not operate without entire exhaust system in place and in proper working condition.



DANGER



POTENTIAL HAZARD



- ◆ In certain conditions gasoline is extremely flammable and highly explosive.

WHAT CAN HAPPEN

- ◆ A static charge can ignite gasoline vapors. A fire or explosion from gasoline can burn you, others, and cause property damage.

HOW TO AVOID THE HAZARD

- ◆ Purchase and store gasoline only in an approved container.
- ◆ Always place gasoline containers on the ground away from your vehicle before filling.
- ◆ Do not fill gasoline containers inside a vehicle or on a truck or trailer bed because interior carpets or plastic truck bed liners may insulate the container and slow the loss of any static charge.
- ◆ When practical, remove gas-powered equipment from the truck or trailer and refuel the equipment with its wheels on the ground.
- ◆ If this is not possible, then refuel such equipment on a truck or trailer from a portable container, rather than from a gasoline dispenser nozzle.
- ◆ If a gasoline dispenser nozzle must be used, keep the nozzle in contact with the rim of the fuel tank or container opening at all times until fueling is complete.



 WARNING 	
POTENTIAL HAZARD	
<ul style="list-style-type: none"> ◆ Gasoline vapor can collect inside enclosed trailers and may be ignited by electrical sparks or hot engine/exhaust components. 	
WHAT CAN HAPPEN	
<ul style="list-style-type: none"> ◆ Explosion and fire may occur, resulting in property damage, personal injury and/or death. 	
HOW TO AVOID THE HAZARD	
<ul style="list-style-type: none"> ◆ Provide adequate ventilation of any enclosed trailer to prevent build up of gasoline vapors, especially at floor level. ◆ Refuel only outdoors, never inside an enclosed trailer. ◆ Be sure all fuel tanks and gasoline storage containers have proper caps installed to prevent spillage and minimize vapor escaping into the trailer. ◆ Do not place any equipment that is leaking gasoline in an enclosed trailer. 	

1.4 OPERATION

Although hazard control and accident prevention are partially dependent upon the design and configuration of the equipment, these factors are also dependent upon the awareness, concern, prudence, and proper training of the personnel involved in the operation, transport, maintenance, and storage of the equipment. It is essential that all Operator Safety Mechanisms be connected and in operating condition prior to use for mowing.

 WARNING 	
POTENTIAL HAZARD	
<ul style="list-style-type: none"> ◆ Hands, feet, hair, clothing, or accessories can become entangled in rotating parts. 	
WHAT CAN HAPPEN	
<ul style="list-style-type: none"> ◆ Contact with rotating parts can cause traumatic amputation or severe lacerations. 	
HOW TO AVOID THE HAZARD	
<ul style="list-style-type: none"> ◆ Do not operate the machine without guards, shields and safety devices in place and working. ◆ Keep hands, feet, hair, jewelry, or clothing away from rotating parts. 	

- 1.4.1 Give complete, undivided attention to the job at hand.
- 1.4.2 Mow only in daylight or in good artificial light, keeping away from holes or hidden hazards. **DO NOT** operate the mower when children or others are in the area.
- 1.4.3 When feasible, avoid operating the equipment in wet grass.
- 1.4.4 Use **EXTREME** caution when mowing and/or turning on slopes as loss of traction and/or tip-over could occur. The operator is responsible for safe operation on slopes.

 DANGER 	
POTENTIAL HAZARD	
<ul style="list-style-type: none"> ◆ Mowing on wet grass or steep slopes can cause sliding and loss of control. 	
WHAT CAN HAPPEN	
<ul style="list-style-type: none"> ◆ Loss of control and/or loss of operator's footing could result in a fall with an arm or leg getting under the mower or engine deck, which may result in serious injury or death. 	
HOW TO AVOID THE HAZARD	
<ul style="list-style-type: none"> ◆ Mow across slopes, never up and down. ◆ Do not mow slopes when grass is wet. ◆ Do not mow near drop-offs or near water. ◆ Do not mow excessively steep slopes. ◆ Reduce speed and use extreme caution on slopes. ◆ Avoid sudden turns or rapid speed changes. 	

- Progressively greater care is needed as the slope increases.
- Watch for ditches, holes, rocks, dips, and rises that change the operating angle, as rough terrain could overturn the machine.
- Remove or mark obstacles such as rocks, tree limbs, etc. from the mowing area. Tall grass can hide obstacles.
- Use extreme care with grass catchers or attachments. These can change the stability of the machine and cause loss of control.

- 1.4.5 Use **EXTREME** caution when backing up. **LOOK BEHIND YOU!!**
- 1.4.6 Stop the blades when crossing surfaces other than grass, if mower must be tilted for transportation, and when transporting the mower to and from the area to be mowed.
- 1.4.7 Never operate the mower with damaged guards, shields, or covers. Always have safety shields, guards, switches, and other devices in place and in proper working condition.
- 1.4.8 **DO NOT** change the engine governor settings or overspeed the engine. Operating an engine at excessive speed may increase the hazard of personal injury.
- 1.4.9 Never attempt to make wheel height adjustments while the engine is running.
- 1.4.10 Start the engine carefully according to instructions with feet well away from the blades.

- 1.4.11 Keep hands, feet, and clothing away from rotating parts while the mower is being operated. Keep clear of the discharge opening at all times.
- 1.4.12 Stop the engine, wait for all moving parts to stop, and remove the spark plug wire(s) and/or remove key:
 - a) Before checking, cleaning, or working on the mower.
 - b) After striking a foreign object (inspect the mower for damage and make repairs before restarting and operating the mower).
 - c) Before clearing blockages.
 - d) Whenever you leave the mower.
- 1.4.13 Stop the engine and wait for all moving parts to stop before refueling.
- 1.4.14 The fuel system is provided with a shut-off valve. The fuel shut-off valve is used to shut off the fuel when:
 - a) The machine will not be used for a few days
 - b) During transport to and from the job
 - c) When parking inside a building
- 1.4.15 This mower was designed for one operator only. Keep all others away from mower during operation.
- 1.4.16 **DO NOT** mow with the discharge deflector raised, removed or altered unless there is a grass collection system or mulch kit in place and working properly.
- 1.4.17 Grass catcher components are subject to wear, damage and deterioration, which could expose moving parts or allow objects to be thrown. Frequently check the components and replace them with the manufacturer's recommended parts when necessary.
- 1.4.18 Be aware of the mower discharge and direct discharge away from others.
- 1.4.19 **DO NOT** operate mower under the influence of alcohol or drugs.
- 1.4.20 Use care when approaching blind corners, shrubs, trees, or other objects that may obscure vision.

1.5 MAINTENANCE AND STORAGE

- 1.5.1 For engine maintenance, follow the engine manufacturer's recommendations precisely as stated in the engine manual.
- 1.5.2 Keep engine and engine area free from accumulation of grass, leaves, excessive grease or oil, and other debris which can accumulate in these areas. These materials can become combustible and may result in a fire.
- 1.5.3 Store fuel in a container specifically designed for this purpose. Store the fuel container in a cool, dry place.
- 1.5.4 Keep the mower and fuel container in locked storage to prevent children from playing or tampering with them.
- 1.5.5 Gasoline powered equipment or fuel containers should not be stored in a basement or any enclosed area where open pilot lights or heat appliances are present.
- 1.5.6 Maximum mowing results and safety can only be achieved if the mower is properly maintained and operated correctly.
- 1.5.7 Check all bolts frequently to maintain proper tightness.
- 1.5.8 Keep all guards, shields and safety devices in place and in safe working condition.
- 1.5.9 Frequently check for worn or damaged components that could create a hazard.
- 1.5.10 All replacement parts must be the same as or equivalent to the parts supplied as original equipment.

1.6 SAFETY SIGNS

- 1.6.1 Keep all safety signs legible. Remove all grease, dirt and debris from safety signs and instructional labels.
- 1.6.2 Safety signs must be replaced if they are missing or illegible.
- 1.6.3 When new components are installed, be sure that current safety signs are affixed to the replaced components.
- 1.6.4 New safety signs may be obtained from your authorized Exmark equipment dealer or distributor or from Exmark Mfg. Co. Inc.
- 1.6.5 Safety signs can be affixed by peeling off the backing to expose the adhesive surface. Apply only to a clean, dry surface. Smooth to remove any air bubbles.
- 1.6.6 Familiarize yourself with the following safety signs and instruction labels. They are critical to the safe operation of your Exmark commercial mower.



PART NO.: 43-8480
LOCATION: Top Surface of Mower Deck on Left and Right Sides



PART NO.: 68-7410
LOCATION: Top of Mower Deck



PART NO.: 98-4387
LOCATION: Center of Handle Bar

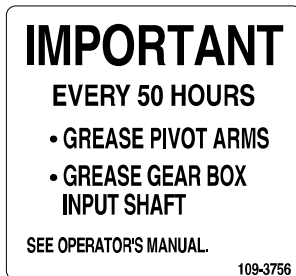

PART NO.: 109-3756
LOCATION: Back of Mower Deck



PART NO.: 98-5954
LOCATION: Top of Mower Deck, Under Belt Cover

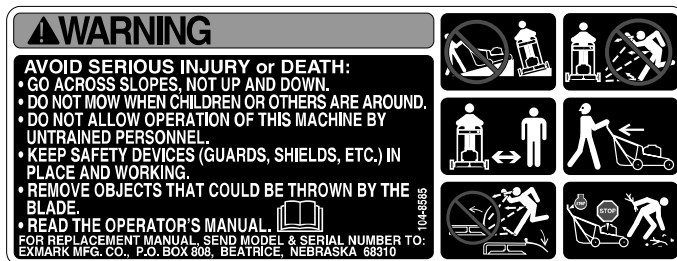

PART NO.: 104-8585
LOCATION: On the Rear Discharge Door



PART NO.: 103-6328
LOCATION: Top Surface of Throttle Control

2. SPECIFICATIONS

2.1 MODEL NUMBER:

For Serial Nos. 561,194 through 599,999; M266KASPC

For Serial Nos. 600,000 and Higher; MS6KA26B

2.2 ENGINE

2.2.1 Engine Specifications: See your engine owner's manual.

2.2.2 RPM (No Load): 3600 rpm

2.3 FUEL SYSTEM

2.3.1 Capacity: 4 qt. (3.8 liter)

2.3.2 Type of Fuel: Use only clean, fresh, regular grade, unleaded gasoline with the pump sticker octane rating of 87 or higher. In countries using the research method, it should be 90 octane minimum.

2.3.3 Fuel Filter: Non-replaceable, on left side of tank.

2.3.4 Fuel Shut Off Valve: in fuel line between tank and engine.

2.4 TRANSMISSION

2.4.1 3 speeds forward

Speed range: 1st - 2.0 mph (3.2 km/h)

2nd - 2.9 mph (4.6 km/h)

3rd - 4.1 mph (6.6 km/h)

2.5 DECK

2.5.1 Cutting Width: 26.1" (66 cm)

2.5.2 Blade Brake: When the blade engagement control is moved to the disengaged position a friction brake pad stops the rotation of the blades.

2.5.3 Cutting Height: Adjusts in 1/2" (.64 cm) increments from 1" to 4" (2.5 cm-10.6 cm).

2.6 DIMENSIONS

2.6.1 Overall Width: 27" (69 cm)

2.6.2 Overall Length and Height (Adjustable):

Handle Setting	Length	Height
High	69" (175.2 cm)	44" (111.8 cm)
Low	73" (185.4 cm)	37.5" (95.3 cm)

2.6.3 Curb Weight: 160 lbs (73 kg)

3. OPERATION INSTRUCTIONS

NOTE: Determine the left and right sides of the machine from the normal operating position.

3.1 CONTROLS

3.1.1 Familiarize yourself with the controls and operation of the unit.

Carefully read the following information about the controls and their operation.

3.1.2 Blade Control Bail:

Located on the upper handle as shown in Figure 1. **When the blade control bail is depressed, the system senses that the operator is in the normal operator's position.**

When the blade control bail is released, the system senses that the operator has moved from the normal operating position and will stop the blade.

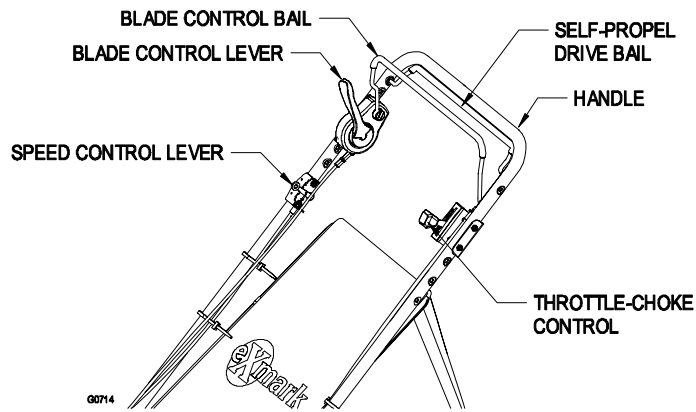

FIGURE 1

3.1.3 Self-Propel Drive Bail:

Located on the upper handle as shown in Figure 1. When the self-propel drive bail is squeezed, the unit will move forward at the speed set on the speed control lever. When this bail is released the unit will stop moving.

3.1.4 Throttle-Choke Control:

The throttle-choke control is located on the left side of the handles as shown in Figure 1. The lever is used to control engine speed. Moving the lever to the full forward **N** (**Choke**) position will place the lever in the choke position. The choke aids in starting a cold engine. Moving the throttle control forward will increase engine speed and moving it to the rear will decrease engine speed.

The throttle-choke control also includes an engine kill position. Moving the lever into the full rearward **STOP** (**Off**) position will kill the engine.

3.1.5 Blade Control Lever:

The blade control lever is located on the right side of the handle next to the Blade Control Bail as shown in Figure 1. Moving the blade control lever into the full forward position while depressing the blade control bail engages the blade. Releasing the blade control bail automatically disengages the blades.

3.1.6 Speed Control Lever:

The ground speed control is located on the right side of the handles below the blade engagement lever as shown in Figure 1. The ground speed control has three settings which control the ground speed of the mower.

3.1.7 Fuel Shut-Off Valve:

The fuel shut off valve, near oil filter, shuts off the flow of fuel when the machine will not be used for a few days, when parking inside a building, and during transport to and from the job. Rotate the valve clockwise to shut off fuel. Rotate the valve counter-clockwise to turn on fuel.

3.2 PRE-START

3.2.1 Refer to Section 4 Maintenance and perform all of the necessary inspection and maintenance steps.

3.2.2 Fill the Fuel Tank with Gasoline:

See Section 1.3 Preparation section for safety information regarding the proper way to handle gasoline.

For best results, use clean, fresh, lead free gasoline with an octane rating of 87 or higher. To ensure freshness, purchase only the quantity of gasoline that you expect to use in 30 days. Using unleaded gasoline results in fewer combustion deposits and longer engine life.

NOTE: Do not add oil to the gasoline.

NOTE: Do not use methanol, gasoline containing methanol, gasohol containing more than 10% ethanol, premium gasoline or white gas. Using these fuels can damage the engine's fuel system.

NOTE: Do not use gasoline that has been stored since the last mowing season or longer.

- a) Clean around the fuel tank cap.

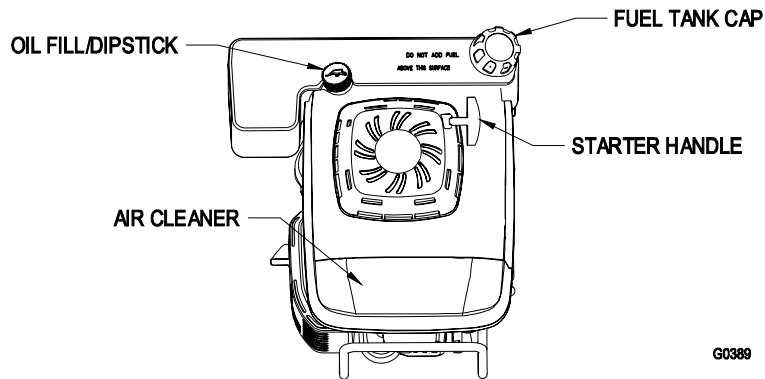

FIGURE 2

- b) Remove the cap from the tank.
- c) Fill the fuel tank with unleaded gasoline to within 1/4 to 1/2 inch (6 to 13 mm) from the top of the tank. Do not fill into the filler neck.

NOTE: Do not fill the tank more than 1/4" (6 mm) from the top of the tank because the gasoline must have room to expand.

- d) Install the fuel tank cap and wipe up any spilled gasoline.

3.2.3 Make sure you understand the controls, their locations, their functions, and their safety requirements.

3.3 OPERATING INSTRUCTIONS

3.3.1 Read the Engine Owner's Manual carefully for detailed operating instructions and maintenance regarding the engine.

Before attempting to operate the unit, refer to Section 1 (Safety) and follow all safety, operating, and preparation guidelines as stated in that section.

3.3.2 Starting the Engine:

- a) Connect the wire to the spark plug. See Figure 3.

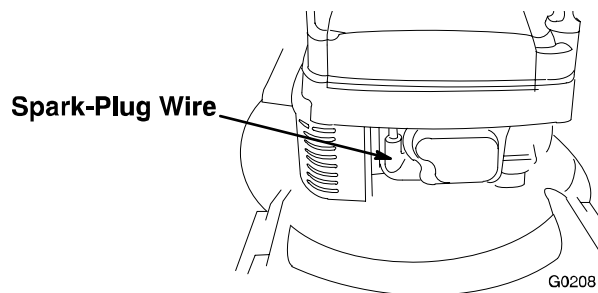

FIGURE 3

- b) Open the fuel valve. The fuel valve is located at the lower left edge of the fuel tank. Rotate the valve counter-clockwise to turn on fuel. (Figure 4)

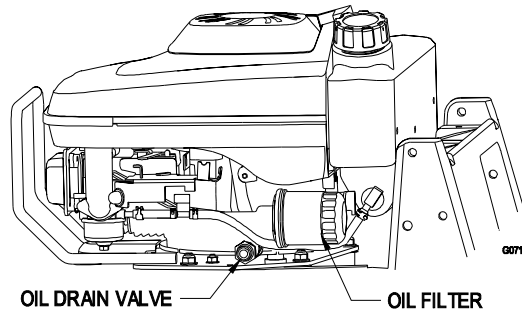

FIGURE 4

- c) Move the throttle-choke control to the **H (Choke)** position.
NOTE: Do not use the choke when the engine is warm.
- d) Pull the starter handle lightly until you feel resistance, then pull it sharply. Allow the rope to return slowly.
- e) When the engine starts, move the throttle control to the **Fast** position, and set the ground speed control as desired.
NOTE: If the engine fails to start after 3 pulls, repeat steps 3-6.

3.3.3 Stopping the Engine:

Release the blade control bail. The blade should stop within 3 seconds. Move the throttle to the **STOP (Off)** position to kill the engine.

NOTE: If the blade does not stop within 3 seconds after releasing the blade control bail, contact an Authorized Service Dealer.

3.3.4 Using the Self-Propel Drive:

The lawn mower has three ground speeds. **1** is slow, **2** is medium, and **3** is fast (See Figure 1 for speed control lever location).

- a) Start the engine.
- b) Using the ground speed control, select the desired ground speed.
- c) Squeeze the drive bail against the handle (See Figure 1).

NOTE: Do not shift speeds while squeezing the ground speed control against the handle. This can damage the transmission. Release the ground speed control before changing speeds.

NOTE: You can vary the ground speed by increasing or decreasing the distance between the ground speed control and the handle. Lower the control bar to decrease the ground speed when you are making a turn or if the lawn mower is moving too fast for you. If you lower the control bar too far the lawn mower stops self-propelling. Squeeze the ground speed control closer to the handle to increase the ground speed. When you hold the ground speed control tight against the handle, the lawn mower self-propels at the maximum ground speed. Move the ground speed control to the **Neutral** position when you use the lawn mower for trimming or whenever you leave the lawn mower.

3.3.5 Operating the Blade Control Lever:

- a) Start the engine.
- b) Squeeze the blade control bail against the handle (Figure 1).
- c) Move the blade control lever to the full forward **Latch** position. Blades should engage (Figure 1).
- d) Release the blade control bail to disengage the blades.

NOTE: The blade control lever will release rapidly when the blade control bail is released. To avoid minor injury, keep hands clear of the blade control lever when the blade control bail is released.

3.3.6 Checking the Blade Brake Clutch:

Check the Blade Brake Clutch (BBC) system before each use to ensure that it is operating properly.

Normal Test:

- a) Stop the engine and wait for all moving parts to stop.
- b) Move the lawn mower onto a paved surface in a non-windy area.
- c) Set all four wheels in to the 2-1/2 in. (64 mm) cutting height (Figure 6).
- d) Set the ground speed selector to the **N (Neutral)** position.
- e) Take a half sheet of newspaper and crumple it into ball small enough to go under the deck (about three inches or 76 mm in diameter) as shown in Figure 5.

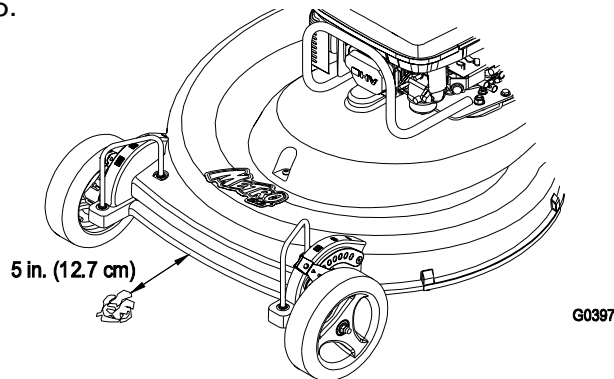



FIGURE 5

- f) Place the ball of newspaper five inches (12.7 cm) in front of the lawn mower (Figure 5).
- g) Start the engine.
- h) Squeeze the blade control bail against the handle.
- i) Move the blade control lever to the full forward **Latch** position. Blades should engage.
- j) Release the blade control bail. You should hear a “bang.” The blade should stop in three seconds.
- k) Immediately push the lawn mower over the newspaper ball.
- l) Stop the engine and wait for all moving parts to stop.
- m) Walk around the lawn mower to check for the newspaper ball. If the ball did not go under the deck, repeat steps g) through l).
- n) Pull the lawn mower away from the newspaper. If the newspaper ball unravels or is shredded, the blade has not properly stopped, resulting in an unsafe operating condition. Contact an Authorized Service Dealer.

 DANGER 	
POTENTIAL HAZARD	
<ul style="list-style-type: none"> ◆ If the blade brake clutch system is inoperative, the blade will continue to rotate when you release the blade control bail. 	
WHAT CAN HAPPEN	
<ul style="list-style-type: none"> ◆ Contact with the blade could occur, causing serious injury. 	
HOW TO AVOID THE HAZARD	
<ul style="list-style-type: none"> ◆ Check the BBC operation before each use. ◆ Never use the BBC-equipped lawn mower with an inoperative safety system. ◆ Take your lawn mower to an Authorized Service Dealer for repair if the safety system fails to operate properly. 	



3.3.7 Test Using the Grass Bag:

- a) Install the empty grass bag on the bag support tabs.
- b) Start the engine.
- c) Squeeze the blade control bail against the handle.
- d) Move the blade control lever to the full forward **Latch** position. The bag should begin to inflate, indicating that the blade is engaged and rotating.
- e) Release the blade control bail. If the bag does not immediately deflate, it indicates that the blade is still rotating. The blade brake clutch mechanism may deteriorating, and, if ignored could result in an unsafe operating condition. Have the lawn mower inspected and serviced by an Authorized Service Dealer.

3.3.8 Adjusting the Cutting Height:

The front wheels are adjusted individually with a wheel height adjustment lever. The rear wheels are adjusted together with the wheel height adjustment lever located above the left rear wheel. The cutting heights are listed in the following table.

Cutting Heights		
1.0 in (25 mm)	1.5 in (38 mm)	2.0 in (51 mm)
2.5 in (64 mm)	3.0 in (76 mm)	3.5 in (89 mm)
	4.0 in (102 mm)	

 DANGER 	
POTENTIAL HAZARD	
<ul style="list-style-type: none"> ◆ Adjusting the cutting height levers could bring your hands into contact with a moving blade. 	
WHAT CAN HAPPEN	
<ul style="list-style-type: none"> ◆ A moving blade can cause serious injury. 	
HOW TO AVOID THE HAZARD	
<ul style="list-style-type: none"> ◆ Stop the engine and wait for all movement to stop before adjusting the cutting height. ◆ Do not put your fingers under the housing when adjusting the cutting height. 	

a) Front Wheel Height Adjustment:

1. Pull the wheel height adjustment lever toward the wheel (Figure 6) and move it to the desired setting.

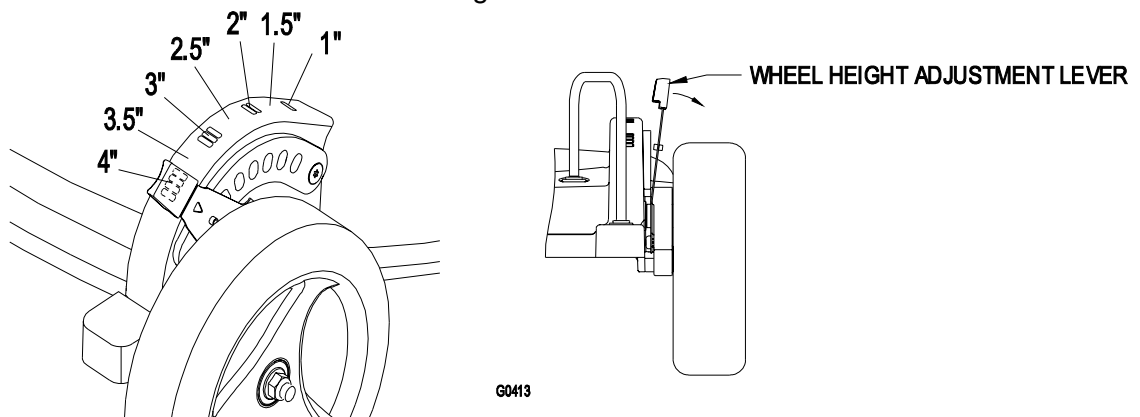

FIGURE 6

2. Release the wheel height adjustment lever and set it securely in the notch.
3. Adjust both front wheels to the same cutting height setting.

b) Rear Wheel Height Adjustment:

1. Pull the rear wheel height adjustment lever outward towards left wheel and move it to the same cutting height setting as the front wheels.
2. Release the rear wheel height adjustment lever and set it securely in the notch.

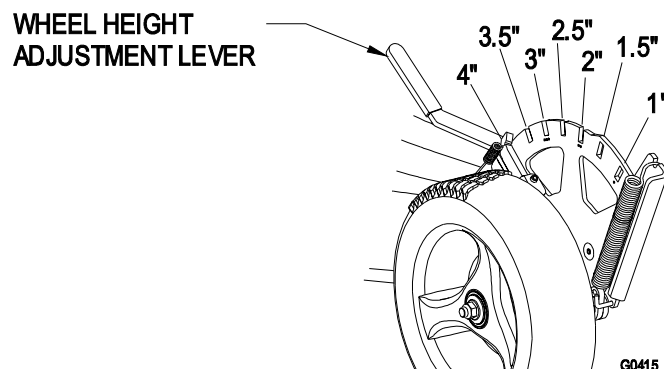

FIGURE 7

3.3.9 Using the Grass Bag:

Occasionally, you may wish to use the grass bag for bagging extra long grass, lush grass, or leaves.

a) Installing the Grass Bag:

1. Stop the engine and wait for all moving parts to stop.
2. Open the rear door.

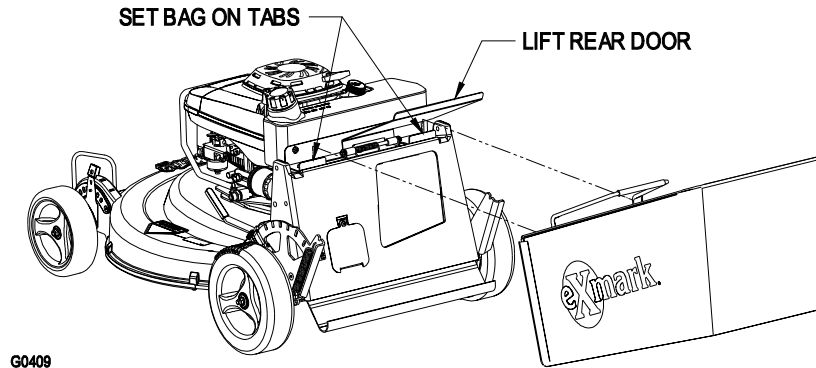



FIGURE 8

3. Set the bag frame onto the bag support tabs.
4. Lower door onto bag.

b) Mowing with the Grass Bag:



 WARNING 	
POTENTIAL HAZARD <ul style="list-style-type: none">◆ A worn grass bag could allow small stones and other similar debris to be thrown in the operator's or bystander's direction.	
WHAT CAN HAPPEN <ul style="list-style-type: none">◆ Thrown objects can result serious personal injury or death to the operator or bystanders.	
HOW TO AVOID THE HAZARD <ul style="list-style-type: none">◆ Check the grass bag frequently. If it is damaged, install a new Exmark replacement bag.	

Cut the grass until the bag is full.

NOTE: Do not overfill the bag.

c) Removing the Grass Bag:

1. Stop the engine and wait for all moving parts to stop.
2. Raise the discharge door.
3. Grasp the bag handle and lift the bag off the lawn mower.
4. Gradually tip the bag forward to empty the clippings.
5. To install the bag, refer to section 3.3.9 a).

 DANGER 	
POTENTIAL HAZARD	
<ul style="list-style-type: none"> ◆ If the discharge door does not close completely, the lawn mower could throw objects. 	
WHAT CAN HAPPEN	
<ul style="list-style-type: none"> ◆ Thrown objects can result serious personal injury or death to the operator or bystanders. 	
HOW TO AVOID THE HAZARD	
<ul style="list-style-type: none"> ◆ Never open the door to the discharge opening when the engine is running. ◆ If you cannot close the door because grass clippings clog the discharge area, stop the engine and clear the obstruction with a stick, not your hand, until you can close the door completely. 	

3.3.10 Operating Tips:

- Review the Safety Instructions (Section 1) and read this manual carefully before operating the lawn mower.
- Set the engine speed to the fastest position for the best cutting results.
- Maintain a sharp blade throughout the cutting season. Periodically file down nicks on the blade. Replace the blade when necessary with an original Exmark replacement blade.
- Clean the air filter frequently. Mulching stirs up more clippings and dust which clogs the air filter and reduces engine performance.

Cutting Grass:

- Grass grows at different rates at different times of the year. In the summer heat, it is best to cut grass at the 2-1/2 inch (64 mm), 3 inch (76 mm), or 3-1/2 inch (90 mm) cutting height settings. Cut only about a third of the grass blade at a time. Do not cut below the 2-1/2 inch (64 mm) setting unless the grass is sparse or it is late fall when grass growth begins to slow down.
- When cutting grass over 6 inches (15 cm) tall, first mow at the highest cutting height setting and walk slower; then mow again at a lower setting for the best lawn appearance. If the grass is too long and the leaves clump on top of the lawn, the lawn mower may plug and cause the engine to stall.
- Alternate the mowing direction. This helps disperse the clippings over the lawn for even fertilization.

If the finished lawn appearance is unsatisfactory, try one or more of the following:

- Sharpen the blade.
- Walk at a slower pace while mowing.
- Raise the cutting height on your lawn mower.
- Cut the grass more frequently.
- Overlap cutting swaths instead of cutting a full swath with each pass.
- Set the cutting height on the front wheels one notch lower than the rear wheels. For example, set the front wheels at 2-1/2 inches (64 mm) and the rear wheels at the 3 inches (76 mm).

Cutting Leaves:

- After cutting the lawn, ensure that half of the lawn shows through the cut leaf cover. You may need to make more than one pass over the leaves.
- For light leaf coverage, set all the wheels at the same cutting height setting.
- If there are more than 5 inches (127 mm) of leaves on the lawn, set the front cutting height 1 or 2 notches higher than the rear cutting height. This makes it easier to feed the leaves under the lawn mower deck.
- Slow down your mowing speed if the lawn mower does not cut the leaves finely enough.
- If you mow over oak leaves, you can add lime to the grass in the spring to reduce the acidity of the oak leaves.

4. MAINTENANCE



NOTE: Determine the left and right sides of the machine from the normal operating position.

Recommended Maintenance Schedule

Service Interval	Maintenance Procedure
Each Use	<ul style="list-style-type: none">• Check the engine oil level.• Check the stopping time of the blade brake. The blade must stop within 3 seconds of releasing the bail; if it does not; contact an Authorized Service Dealer for repair.• Remove grass clippings and dirt from under the housing.• Clean the discharge tunnel area
8 Hours	<ul style="list-style-type: none">• Check the blade and the engine mounting fasteners. Tighten them if they are loose.• Check BBC tension.
50 Hours	<ul style="list-style-type: none">• Change the engine oil (without the oil filter).¹• Sharpen or replace the blade; maintain it more frequently if the edge dulls quickly in rough or in sandy conditions.• Clean the blade brake clutch shield.• Check for leaks in the fuel system and/or a deteriorating fuel hose. Replace parts if necessary.• Remove grass clippings and debris from under the belt cover.• Lubricate the gear case.• Lubricate the pivot arms.
75 Hours	<ul style="list-style-type: none">• Adjust the self-propel drive system.
100 Hours	<ul style="list-style-type: none">• Change the oil filter.• Inspect the spark plug and replace it if necessary.• Clean the cooling system; remove grass clippings, debris, or dirt from the engine air cooling fins and starter. Clean the system more frequently in dirty or high-chaff conditions.• Adjust the blade brake cable.• Service the wheels.
300 Hours	<ul style="list-style-type: none">• Replace the paper air filter. Replace it more frequently in dusty operating conditions.
Storage	<ul style="list-style-type: none">• Empty the fuel tank before repairs as directed or before storage.

¹Change the engine oil after the first 5 operating hours.

NOTE: Refer to your engine operator's manual for additional maintenance procedures.

 CAUTION 	
POTENTIAL HAZARD	
<ul style="list-style-type: none"> ◆ If you leave the wire on the spark plug, someone could accidentally start the engine. 	
WHAT CAN HAPPEN	
<ul style="list-style-type: none"> ◆ Accidental starting of the engine could seriously injure you or other bystanders. 	
HOW TO AVOID THE HAZARD	
<ul style="list-style-type: none"> ◆ Disconnect the wire from the spark plug before you don any maintenance. Set the wire aside so that it does not accidentally contact the spark plug. 	

4.1 Checking the Engine Oil Level:

Service Interval: Before each use.

Make sure that the oil level is between the Add and the Full marks as shown on the dipstick (Figure 9). If the oil level is below the Add mark, add oil. Use only high-quality SAE 30 or SAE 10W-30 weight detergent oil that has the American Petroleum Institute (API) service classification SF, SG, SH, or SJ.

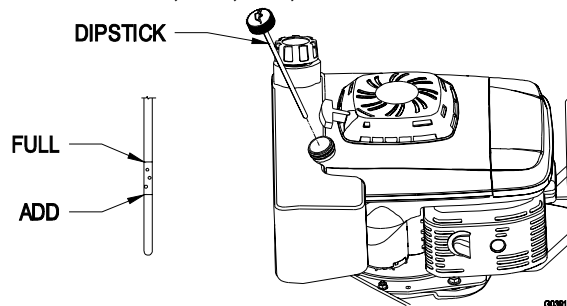

FIGURE 9

4.2 Checking the Blade Brake Clutch:

Refer to Section 3.3.6 Checking the Blade Brake Clutch.

4.3 Cleaning the Underside of the Lawn Mower Housing:

To ensure the best performance, keep the underside of the lawn mower housing clean (Figure 10).

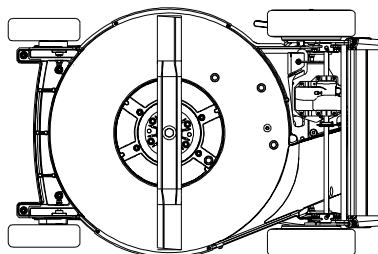

FIGURE 10

Washing Method

- a) Position the lawn mower on a flat concrete or asphalt surface near a garden hose.
- b) Start the engine.

- c) Hold the running garden hose a handle level and direct the water to flow on the ground just in front of the right rear tire (Figure 11).

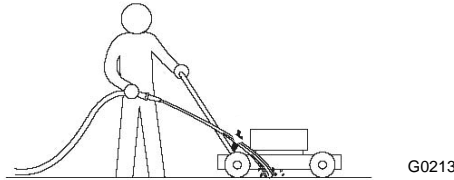

FIGURE 11

- d) Engage the blade.



NOTE: The blade will draw in water and wash out clippings. Let the water run until you no longer see clipping being washed out from under the housing.

- e) Disengage the blade, stop the engine and wait for all moving parts to stop.
- f) Turn off the water.
- g) Start the lawn mower, engage the blade, and let the lawn mower run for a few minutes to dry out its components.

Scraping Method

If washing does not remove all debris from under the lawn mower, scrape it clean.

- a) Disconnect the wire from the spark plug.
- b) Drain the fuel from the fuel tank. Refer to section 4.8, Emptying the Fuel Tank and Cleaning the Fuel Filter.



 WARNING 	
POTENTIAL HAZARD	
<ul style="list-style-type: none"> ◆ Tipping the lawn mower may cause the fuel to leak from the carburetor or the fuel tank. 	
WHAT CAN HAPPEN	
<ul style="list-style-type: none"> ◆ Gasoline is extremely flammable, highly explosive, and under certain conditions, can cause personal injury or property damage. 	
HOW TO AVOID THE HAZARD	
<ul style="list-style-type: none"> ◆ Avoid fuel spills by running the engine dry or by removing the gasoline with a hand pump; never siphon. 	

- c) Tip the lawn mower onto its **right** side.
- d) Remove the dirt and grass clippings with a hardwood scraper. Avoid burrs and sharp edges.
- e) Turn the lawn mower upright.
- f) Fill the fuel tank.
- g) Connect the wire to the spark plug.

4.4 Cleaning the Discharge Tunnel:

Service Interval: After each use.

Always be sure that the discharge tunnel door closes securely when you remove the bag. If the debris prevents the discharge door from closing securely, clean the inside of the discharge tunnel and the door thoroughly.

 WARNING 	
POTENTIAL HAZARD	
◆ Grass clippings and other objects can be thrown from an open discharge tunnel.	
WHAT CAN HAPPEN	
◆ Thrown objects can cause serious injury or kill the operator or bystanders.	
HOW TO AVOID THE HAZARD	
◆ Never start or operate the lawn mower unless the grass bag is locked in place.	

4.5 Servicing the Air Filter:

Service Interval: Clean the foam pre-cleaner every 25 operating hours.

Replace the paper air filter once every season or every 300 operating hours (more frequently in dusty conditions).

NOTE: Do not operate the engine without the air filter assembly; extreme engine damage will occur.

- a) Stop the engine and wait for all moving parts to stop.
- b) Disconnect the wire from the spark plug (Figure 3).
- c) Remove the screw that secures the air cleaner cover (Figure 12.)

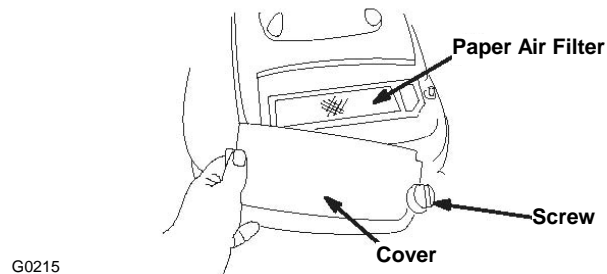

FIGURE 12

- d) Remove the cover and clean it thoroughly (Figure 12).
- e) Remove the paper air filter and discard it as required (Figure 13).

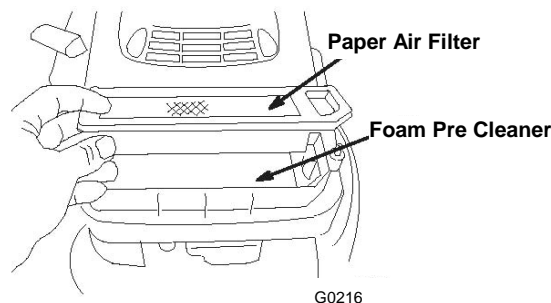

FIGURE 13

NOTE: Do not try to clean a paper air filter.

- f) Remove the foam pre-cleaner and wash it with a mild detergent and water, then blot it dry (Figure 13).
- g) Saturate the pre-cleaner with clean engine oil, then squeeze it (do not twist) to remove the excess oil.

- h) Install the foam pre-cleaner.
- i) Install the new paper air filter.
- j) Install the cover and secure it with the screw.

4.6 Maintaining the Blade:

Always mow with a sharp blade. A sharp blade cuts cleanly and without tearing or shredding the grass blades.

- a) Stop the engine and wait for all moving parts to stop.
- b) Disconnect the wire from the spark plug (Figure 3).
- c) Drain the gasoline from the fuel tank.
- d) Tip the lawn mower onto its **right** side (Figure 14).

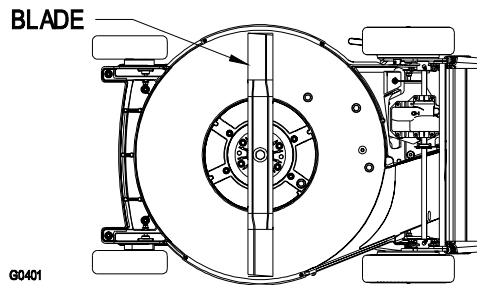
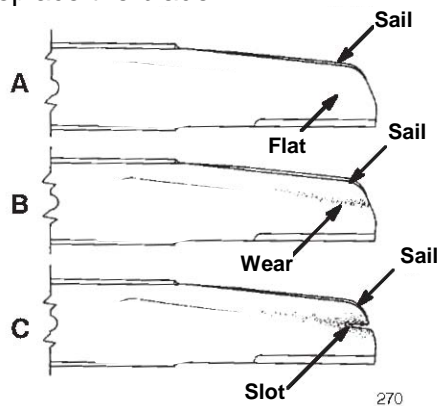

FIGURE 14



- e) Inspect the Blade for sharpness and wear, especially where the flat and the curved parts meet (Figure 15A). Because sand and abrasive material can wear away the metal that connects the flat and curved parts of the blade, check the blade before using the lawn mower. If you notice a slot or wear (Figure 15B and 15C), replace the blade.



G0219

FIGURE 15

NOTE: For the best performance, install a new blade before the cutting season begins. During the year, file down any small nicks to maintain the cutting edge.

 DANGER 	
POTENTIAL HAZARD	
◆ A worn or damaged blade can break.	
WHAT CAN HAPPEN	
◆ A piece of the blade could be thrown into the operator's or bystander's area, resulting in serious personal injury or death.	
HOW TO AVOID THE HAZARD	
◆ Inspect the blade periodically for wear or damage.	
◆ Replace a worn or damaged blade.	

If it is necessary to remove the blade for replacement or sharpening, complete the following steps:

- f) Remove the blade. Make sure to grasp the end of the blade using a rag or a thickly padded glove. Place a wrench on the top spindle nut and remove the blade bolt (Figure 16).

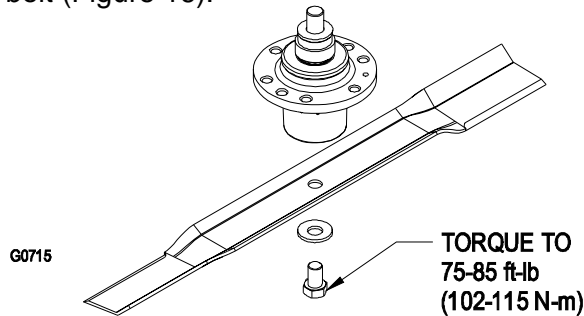

FIGURE 16

- g) *For Sharpening:* File the top side of the blade to maintain its original cutting angle (Figure 17A) and inner cutting edge radius (Figure 17B). The blade will remain balanced if you remove the same amount of material from both cutting edges.

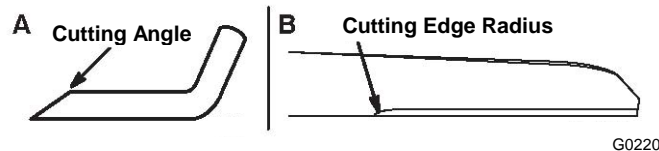

FIGURE 17

- h) Check the balance of the blade by placing the center hole of the blade over a nail or screwdriver shank clamped horizontally in a vise (Figure 18). If either end of the blade rotates downward, file that end (not the cutting edge). The blade is properly balanced when neither end drops.

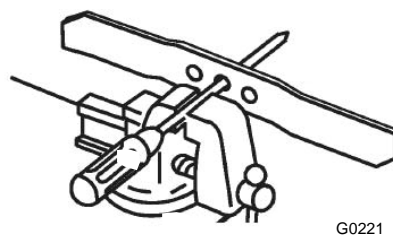

FIGURE 18

- i) Re-install a sharp balanced Exmark blade, spacer, washers, and blade bolt as shown in Figure 16. The sail of the blade must point toward the top of the lawn mower housing for proper installation. Torque the blade bolt to 75-85 ft-lb (102-115 N-m).
- j) Return the lawn mower to its upright position.
- k) Close fuel valve and refuel.
- l) Connect the wire to the spark plug.

4.7 Cleaning Under the Cover:

- a) Stop the engine and wait for all moving parts to stop.
- b) Disconnect the wire from the spark plug (Figure 3).
- c) Remove the screw that secures the belt cover to the lawn mower housing (Figure 19).

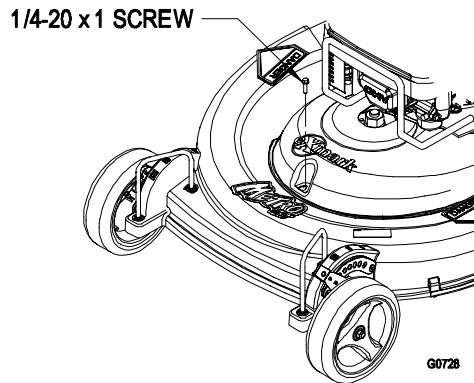

FIGURE 19

- d) Push down on the belt cover on each side of the engine and lift off the cover. Brush out all the debris around the belt area.
- e) Re-install the belt cover.
- f) Connect the wire to the spark plug.

4.8 Emptying the Fuel Tank and Cleaning the Fuel Filter:

Service Interval: Clean the fuel filter element every 100 operating hours.

The fuel filter (screen) element is located inside the fuel tank.

- a) Stop the engine and wait for it to cool down.
- NOTE:** Drain gasoline for a cold engine only.
- b) Disconnect the wire from the spark plug (Figure 3).
 - c) Close the fuel valve located in the fuel line between the engine and tank by rotating clockwise.
 - d) Disconnect the fuel line (Figure 20) by loosening the tube clamp at the carburetor.

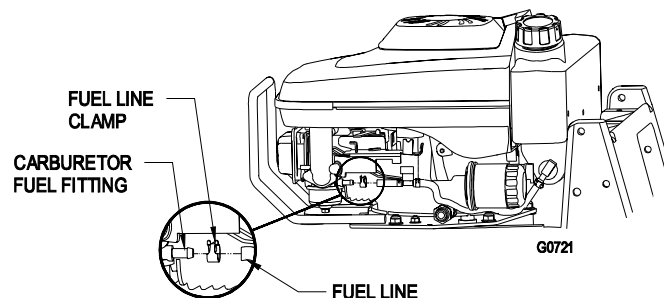

FIGURE 20

- e) Open the fuel valve to the open position.
- f) Drain the gasoline completely from the tank and fuel line into an approved fuel container.
- g) Remove the fuel tank from the mower.
- h) Close the fuel valve.
- i) Pour a small amount of fuel in the fuel tank, move the fuel around in the tank, and pour it out into an approved fuel container.
- j) Install the fuel tank and fuel line.

4.9 Lubricating the Pivot Arms:

Service Interval: Lubricate after every 50 operating hours or when the season ends.

- a) Move the rear wheel cutting height levers to the center setting.
- b) Locate the grease fitting on the underside of the mower deck. Wipe the grease fittings with a clean rag (Figure 21).

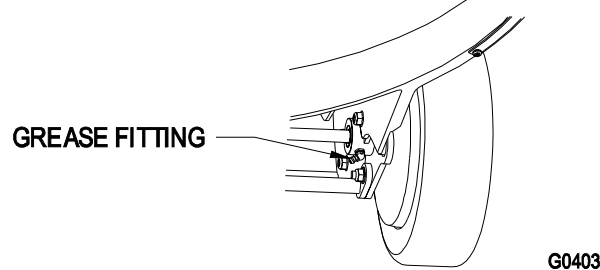

FIGURE 21

- c) Install a grease gun onto the fitting and gently apply 2 or 3 pumps of #2 multi-purpose lithium base grease (Figure 21).

NOTE: Excessive grease pressure may damage the seals.

4.10 Adjusting the Self-Propel Drive:

NOTE: Improper adjustment can cause transmission failure.

- a) If the lawn mower does not self-propel or has a tendency to creep forward when the control bar is released, adjust the transmission cable on the deck.
- b) If the lawn mower does not self propel, rotate the transmission cable nuts clockwise 1/2 turn to tighten the belt.
- c) If the lawn mower creeps forward, rotate the transmission cable nuts 1/2 turn counterclockwise to loosen the belt (Figure 22).
- d) If the lawnmower does not drive up slopes, you may need to increase belt tension. Repeat step b).

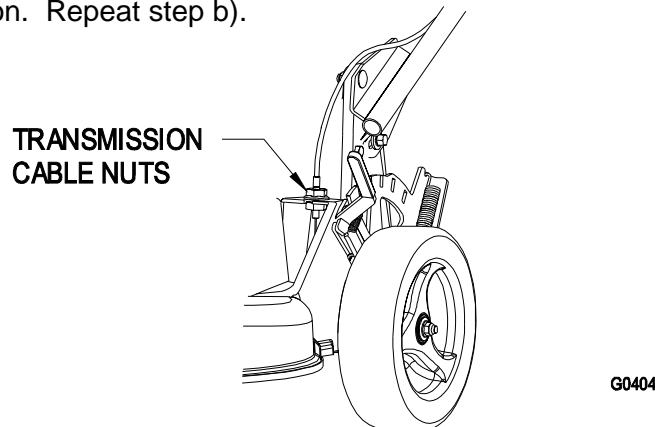

FIGURE 22

4.11 Servicing the Spark Plug:

Service Interval: Check the spark plug after every 100 operating hours.

- a) Stop the engine and wait for all moving parts to stop.
- b) Disconnect the wire from the spark plug (Figure 3).
- c) Clean around the spark plug.
- d) Remove the spark plug from the cylinder head.

NOTE: Replace a cracked, fouled, or dirty spark plug. Do not clean the electrodes because grit entering the cylinder can damage the engine.

- e) Set the gap on the plug to 0.030 in. (0.76 mm) (Figure 23).

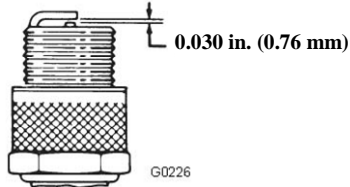

FIGURE 23

- f) Install the spark plug and the gasket seal.
- g) Torque the plug to 17 ft-lb (23 N-m).
- h) Connect the wire to the spark plug.



4.12 Changing the Engine Oil:

Service Interval: Change the oil after the first 5 operating hours (or the first month).

Then after every 50 operating hours (or every 6 months).

- a) Run the engine to warm the engine oil.

NOTE: Warm oil flows better and carries more contaminants.

 WARNING 	
POTENTIAL HAZARD	
◆ Oil may be hot after engine has been run.	
WHAT CAN HAPPEN	
◆ Contact with hot oil can cause severe personal injury.	
HOW TO AVOID THE HAZARD	
◆ Avoid contacting the hot engine oil when you drain it.	

- b) Stop the engine and wait for all moving parts to stop.
- c) Disconnect the wire from the spark plug (Figure 3).
- d) Place a suitable drain pan under the oil drain (Figure 24).
- e) Open the oil drain valve.
- f) After draining the oil, close the oil drain valve.
- g) Fill the crankcase with fresh oil to the upper limit mark on the dipstick.
- h) Insert the dipstick into the filler neck and rotate the cap clockwise until it is tight.
- i) Wipe up any spilled oil.
- j) Connect the wire to the spark plug.
- k) Recycle the used oil according to local codes.

4.13 Changing the Oil Filter:

Service Interval: Replace the oil filter after every 100 operating hours.

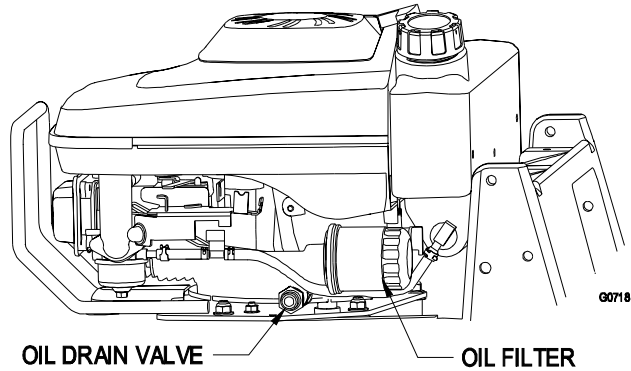



FIGURE 24

- a) Run the engine to warm the oil.

	WARNING	
POTENTIAL HAZARD		
◆ Oil may be hot after engine has been run.		
WHAT CAN HAPPEN		
◆ Contact with hot oil can cause severe personal injury.		
HOW TO AVOID THE HAZARD		
◆ Avoid contacting the hot engine oil when you drain it.		

- a) Stop the engine and wait for all moving parts to stop.
b) Disconnect the wire from the spark plug (Figure 3).
c) Drain the engine oil.
d) Place a rag under the oil filter to catch any oil that may leak out as you remove the filter.
e) Remove the oil filter.
f) Use your finger to coat the gasket on the new filter with clean engine oil.

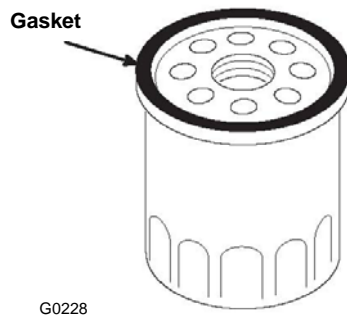

FIGURE 25

- g) Install the new filter and hand tighten it 2/3 turn only.
h) Fill the crankcase to the Full line on the dipstick with fresh oil.
i) Connect the wire to the spark plug.
j) Run the engine for about 3 minutes.

- k) Stop the engine, wait for all moving parts to stop, and check for oil leakage around the filter.
- l) Add oil to compensate for the oil in the oil filter.
- m) Recycle the used oil filter according to local codes.

4.14 Lubricating the Gear Case:

NOTE: Lubricating the gear case as specified will yield maximum gear case life.

Service Interval: After every 50 operating hours, grease the gear case.

- a) Remove the grass bag.
- b) Remove the gear case access cover.
- c) Install a grease gun onto the fitting through the gear case access cover opening (Figure 26).

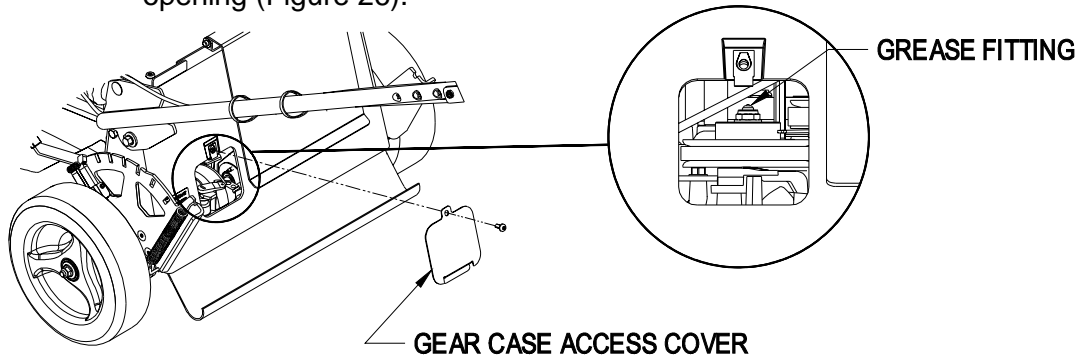

FIGURE 26

G0411

- d) Gently apply one to two pumps of #2 multi-purpose lithium-base grease.
- e) Re-install gear case access cover.
- f) Install the grass bag.

4.15 Adjusting the Blade Brake Cable:

Service Interval: Adjust whenever a new blade brake cable assembly is installed, new blade drive belt is installed, and/or the cut quality is diminishing.

- a) Stop the engine and wait for all moving parts to stop.
- b) Disconnect the wire from the spark plug (Figure 3).
- c) Remove belt cover.
- d) Loosen the blade brake cable nuts until the cable conduit slides (Figure 27).

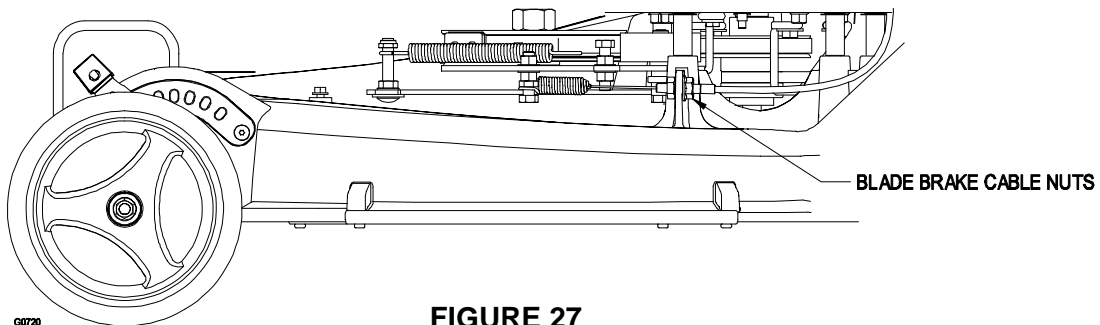

FIGURE 27

- e) Pull the cable to remove the slack, but do not put tension on the spring.
- f) Tighten the blade brake cable nut to lock the adjustment in place.
- g) Check adjustment by activating BBC. The extended spring should measure between 1.75" and 2.00" (see Figure 28).

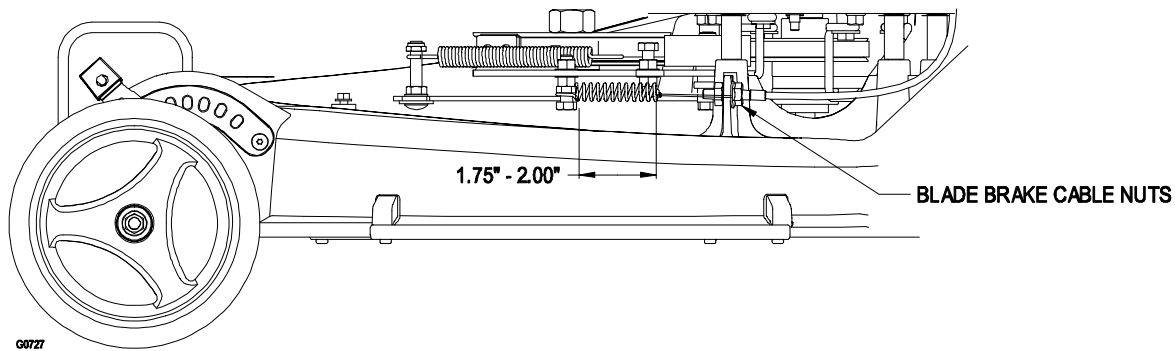

FIGURE 28

- h) Re-install the belt cover.
- i) Connect the wire to the spark plug.

4.16 Servicing the Wheels:

Removing the Wheels:

- a) Stop the engine and wait for all moving parts to stop.
- b) Disconnect the wire from the spark plug (Figure 3).
- c) Remove the hardware as shown (Figure 29 & 30).

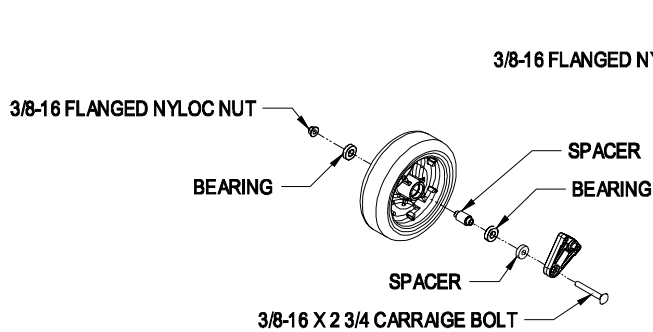

**FRONT WHEEL ASSEMBLY
FIGURE 29**

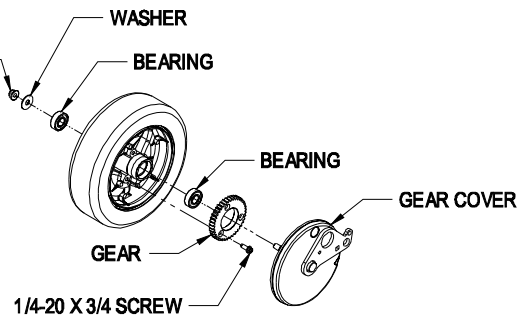

**REAR WHEEL ASSEMBLY
FIGURE 30**

Assembling the Wheels:



- a) Re-install wheel assembly as shown in Figures 29 or 30.
- b) Connect the wire to the spark plug.

5. STORAGE

5.1 Preparing the fuel system.

To prepare the lawn mower for off season storage, perform the recommended maintenance procedures.

Store the lawn mower in a cool, clean, dry place. Cover the lawn mower to keep it clean and protected.

 WARNING 
POTENTIAL HAZARD <ul style="list-style-type: none"> ◆ Gasoline can vaporize if you store it over long periods of time.
WHAT CAN HAPPEN <ul style="list-style-type: none"> ◆ Gasoline vapors can explode if they come into contact with an open flame.
HOW TO AVOID THE HAZARD <ul style="list-style-type: none"> ◆ Do not store gasoline over long periods of time. ◆ Do not store the lawn mower with gasoline in the fuel tank or the carburetor in an enclosure with an open flame. (For example, a furnace or a water heater pilot light.) ◆ Allow the engine to cool before storing it in any enclosure.

Empty the fuel tank when mowing the last time before storing the lawn mower.

- a) Run the lawn mower until the engine stops from running out of fuel.
- b) Prime the engine and start it again.
- c) Allow the engine to run until it stops. When you can no longer start the engine it is sufficiently dry.

5.2 Preparing the Engine

- a) While the engine is still warm, change the oil from the crankcase. Refer to Section 4.13 Changing the Engine Oil.
- b) Remove the spark plug (Figure 3).
- c) Using an oil can, add about one tablespoon of oil to the crankcase through the spark plug hole.
- d) Slowly rotate the engine several times, using the starter rope, to distribute the oil.
- e) Install the spark plug but **do not** connect the wire to the spark plug.

5.3 General Storage Information

- a) Clean the lawn mower housing. Refer to Section 4.3 Cleaning the Underside of the Lawn Mower Housing.
- b) Clean any dirt and chaff from the cylinder, cylinder head fins, and blower housing.
- c) Remove grass clippings, dirt, and grime from the external parts of the engine, the shrouding, and the top of the lawn mower housing.
- d) Refer to Section 4.7 Cleaning the Under the Cover.
- e) Check the condition of the blade. Refer to Section 4.6 Maintaining the Blade.
- f) Service the air filter. Refer to Section 4.5 Servicing the Air Filter.
- g) Lubricate the pivot arms. Refer to Section 4.9 Lubricating the Pivot Arms.
- h) Tighten all nuts, bolts, and screws.
- i) Touch up all rusted or chipped paint surfaces with paint available from an Authorized Service Dealer.

5.4 Removing the Lawn Mower from Storage

- a) Check and tight all fasteners.
- b) Remove the spark plug and spin the engine rapidly by pulling the starter rope to blow excess oil fro the cylinder.
- c) Clean the spark plug or replace it if it is cracked, broken, or if the electrodes are worn.
- d) Install the spark plug and torque it to 17 ft-lb (23 N-m).
- e) Perform any needed maintenance procedures.
- f) Fill the fuel in the fuel tank with fresh gasoline.
- g) Check the engine oil level.
- h) Connect the wire to the spark plug.

6. ACCESSORIES

MK26 – Mulch Kit

7. TROUBLESHOOTING

Exmark designed and built your lawn mower for trouble free operation. Check the following components and items carefully, and refer to Section 4 Maintenance for more information. If a problem continues, contact an Authorized Service Dealer.

Problem	Possible Causes	Corrective Action
Engine does not start	<ol style="list-style-type: none"> 1. The fuel tank is empty or the fuel system contains stale fuel. 2. The throttle lever is not in the Choke position. 3. The wire is not connected to the spark plug. 4. The spark plug is pitted, fouled, or the gap is incorrect. 	<ol style="list-style-type: none"> 1. Drain and/or fill the fuel tank with fresh gasoline. If the problem persists, contact an Authorized Service Dealer. 2. Move the throttle lever to the Choke position. 3. Connect the wire to the spark plug. 4. Check the spark plug and adjust the gap if necessary. Replace the spark plug if it is pitted, fouled, or cracked.
Problem	Possible Causes	Corrective Action
Engine starts hard or loses power	<ol style="list-style-type: none"> 1. The fuel tank contains stale fuel. 2. The fuel cap vent hole is plugged. 3. The air filter element is dirty and is restricting the air flow. 4. The underside of the lawn mower deck contains clippings and debris. 5. The spark plug is pitted, fouled, or the gap is incorrect. 6. The engine oil level is low or the oil is dirty. 	<ol style="list-style-type: none"> 1. Drain and fill the fuel tank with fresh gasoline. 2. Clean the fuel cap vent hole or replace the fuel cap. 3. Clean the air filter pre-cleaner and/or replace the paper air filter. 4. Clean the underside of the lawn mower deck. 5. Check the spark plug and adjust the gap if necessary. Replace the spark plug if it is pitted, fouled, or cracked. 6. Check the engine oil. Change the oil if it is dirty or add oil if it is low.

Engine runs rough	<ol style="list-style-type: none"> 1. The wire is not connected to the spark plug. 2. The spark plug is pitted, fouled, or the gap is incorrect. 3. The throttle lever is not in the Fast position. 4. The air filter element is dirty and is restricting the air flow. 	<ol style="list-style-type: none"> 1. Connect the wire to the spark plug. 2. Check the spark plug and adjust the gap if necessary. Replace the spark plug if it is pitted, fouled, or cracked. 3. Move the throttle lever to the Fast position. 4. Clean the air filter pre-cleaner and/or replace the paper air filter.
Lawn mower or engine vibrates excessively	<ol style="list-style-type: none"> 1. The blade is bent or is out of balance. 2. The blade mounting bolt is loose. 3. The underside of the lawn mower deck contains clippings and debris. 4. The engine mounting bolts are loose. 	<ol style="list-style-type: none"> 1. Balance the blade. If the blade is bent, replace it. 2. Tighten the blade mounting bolt. 3. Clean the underside of the lawn mower deck. 4. Tighten the engine mounting bolts.
Uneven cutting pattern	<ol style="list-style-type: none"> 1. All four wheels are not at the same height. 2. The blade is dull. 3. You are mowing in the same pattern repeatedly. 4. The underside of the lawn mower deck contains clippings and debris. 	<ol style="list-style-type: none"> 1. Place all four wheels at the same height. 2. Sharpen and balance the blade. 3. Change the mowing pattern. 4. Clean the underside of the lawn mower deck.
Mower doesn't cut grass	<ol style="list-style-type: none"> 1. The blade disengages while mowing. 2. The blade drive belt is worn or broken. 	<ol style="list-style-type: none"> 1. Replace blade drive belt. 2. Replace blade drive belt. Check adjustment of BBC.

Problem	Possible Causes	Corrective Action
Discharge chute plugs	<ol style="list-style-type: none"> 1. The throttle lever is not in the Fast position. 2. The cutting height is too low. 3. You are mowing too fast. 4. The grass is wet. 5. The underside of the lawn mower deck contains clippings and debris. 	<ol style="list-style-type: none"> 1. Move the throttle lever to the Fast position. 2. Raise the cutting height. 3. Slow down. 4. Allow the grass to dry before mowing. 5. Clean the underside of the lawn mower deck.
Lawn mower does not self-propel	<ol style="list-style-type: none"> 1. The self-propel drive cable is out of adjustment or is damaged. 	<ol style="list-style-type: none"> 1. Adjust the self-propel drive cable. Replace the cable if necessary.

8.

**2-Year Limited Warranty
Exmark Turf Equipment**

(For units purchased on or after October 1, 2004)

Conditions and Products Covered

Exmark Mfg. Co. Inc. and its affiliate, Exmark Warranty Company, pursuant to an agreement between them, jointly warrant on the terms and conditions herein, that we will repair, replace or adjust any part manufactured by Exmark and found by us (in the exercise of our reasonable discretion) to be defective in factory materials or workmanship for a period of two years.

This warranty applies to Exmark turf equipment purchased on or after October 1, 2004 sold in the US or Canada. This warranty may only be assigned or transferred to a second (or third) owner by an authorized Exmark dealer. The warranty period commences upon the date of the original retail purchase.

<u>Products</u>	<u>Warranty Period</u>
• All Products (except as noted below)	2 years
• All Attachments and Accessories	1 year
• Metro 21 and Metro 26 Series	1 year
• Belts and Tires	90 days
• Battery	1 Year Prorated
• Engine*	Warranty is covered by engine manufacturer

*Please refer to the engine manufacturer's warranty statement that is included in the literature packet. We are not authorized to handle warranty adjustments on engines.

This warranty only includes the cost of parts and labor.

Items and Conditions Not Covered

This warranty does not cover the following:

- Pickup and delivery charges to and from any authorized Exmark Service Dealer.
- Any damage or deterioration due to normal use, wear and tear, or exposure.
- Cost of regular maintenance service or parts, such as filters, fuel, lubricants, tune-up parts, and adjustments.
- Any product or part which has been altered or misused or required replacement or repair due to normal wear, accidents, or lack of proper maintenance.
- Any repairs necessary due to use of parts, accessories or supplies, including gasoline, oil or lubricants, incompatible with the turf equipment or other than as recommended in the operator's manual or other operational instructions provided by Exmark.

All warranty work must be performed by an authorized Exmark Service Dealer using Exmark approved replacement parts.

Instructions for Obtaining Warranty Service

1. Contact any Exmark Service Dealer to arrange service at their dealership. To locate a dealer convenient to you, access our website at www.exmark.com. U.S. Customers may also call 402-223-6375.
2. Bring the product and your proof of purchase (sales receipt) to the Exmark Service Dealer.

If for any reason you are dissatisfied with the Service Dealer's analysis or with the assistance provided, contact us at:

Exmark Customer Service Department
The Exmark Warranty Company
2101 Ashland Avenue
Beatrice, NE 68310
402-223-6375 or
service@exmark.com

Owner's Responsibilities

The Exmark turf equipment, including any defective part, must be returned to an authorized Exmark service dealer within the warranty period. This warranty extends only to turf equipment operated under normal conditions. You must properly service and maintain your Exmark product as described in the operator's manual. Such routine maintenance, whether performed by a dealer or by you, is at your expense.

As a condition to this warranty, customer shall have read the operator's manual and shall have completed and submitted to Exmark Warranty Company, within the prescribed time, the Exmark warranty registration.

General Conditions

The sole liability of Exmark and Exmark Warranty Company with respect to this warranty shall be repair and replacement as set forth herein. **Neither Exmark nor Exmark Warranty Company shall have any liability for any other cost, loss or damage, including but not limited to, any incidental or consequential loss or damage.**

In particular, we shall have no liability or responsibility for:

- Expenses related to gasoline, oil or lubricants.
- Travel time, overtime, after hours time or other extraordinary repair charges or charge relating to repairs or replacements outside of normal business hours at the place of business of the authorized Exmark service dealer.
- Rental of like or similar replacement equipment during the period of any warranty, repair or replacement work.
- Any telephone or telegram charges or travel charges.
- Loss or damage to person or property other than that covered by the terms of this warranty.
- Any claims for lost revenue, lost profit or additional cost as a result of a claim of breach of warranty.
- Attorney's fees.

No Claim of breach of warranty shall be cause for cancellation or rescission of the contract of sale of any Exmark mower.

There are no understandings, agreements, representations, or warranties, express or implied, including but not limited to any regarding the merchantability (that product is fit for ordinary use) or fitness for use (that product is fit for a particular purpose), not specified herein, respecting the equipment which is the subject of this warranty.

Some states do not allow exclusions of incidental or consequential damages, or limitations on how long an implied warranty lasts, so the above exclusions and limitations may not apply to you.

This warranty gives you specific legal rights, and you may also have other rights which vary from state to state.

9. Evaporative Emission Control Warranty Statement
California Evaporative Emission Control Warranty Statement
Your Warranty Rights and Obligations

Introduction

The California Air Resources Board and Exmark Manufacturing Company are pleased to explain the evaporative emission control system's warranty on your 2006 model year equipment. In California, new equipment that uses small off-road engines must be designed, built, and equipped to meet the State's stringent anti-smog standards. Exmark Manufacturing Company must warrant the evaporative emission control system on your equipment for two years provided there has been no abuse, neglect or improper maintenance of your equipment.

Your evaporative emission control system may include parts such as: fuel lines, fuel line fittings, and clamps.

Manufacturer's Warranty Coverage:

This evaporative emission control system is warranted for two years. If any evaporative emission-related part on your equipment is defective, the part will be repaired or replaced by Exmark Manufacturing Company.

Owner's Warranty Responsibilities:

- As the equipment owner, you are responsible for performance of the required maintenance listed in your Operator's Manual. Exmark Manufacturing Company recommends that you retain all receipts covering maintenance on your equipment, but Exmark Manufacturing Company cannot deny warranty solely for the lack of receipts.
- As the equipment owner, you should however be aware that Exmark Manufacturing Company may deny you warranty coverage if your emission warranty parts have failed due to abuse, neglect, or improper maintenance or unapproved modifications.
- You are responsible for presenting your equipment to an Authorized Service Dealer as soon as the problem exists. The warranty repairs should be completed in a reasonable amount of time, not to exceed 30 days. If you have a question regarding your warranty coverage, you should contact Exmark Manufacturing Company at 1-402-223-6375.

Defects Warranty Requirements:

1. The warranty period begins on the date the engine or equipment is delivered to an ultimate purchaser.
2. General Evaporative Emissions Warranty Coverage. The emission warranty parts must be warranted to the ultimate purchaser and any subsequent owner that the evaporative emission control system when installed was:
 - A. Designed, built, and equipped so as to conform with all applicable regulations; and
 - B. Free from defects in materials and workmanship that causes the failure of a warranted part for a period of two years.
3. The warranty on evaporative emissions-related parts will be interpreted as follows:
 - A. Any warranted part that is not scheduled for replacement as required maintenance in the written instructions must be warranted for the warranty period of two years. If any such part fails during the period of warranty coverage, it must be repaired or replaced by Exmark Manufacturing Company. Any such part repaired or replaced under the warranty must be warranted for a time not less than the remaining warranty period.
 - B. Any warranted part that is scheduled only for regular inspection in the written instructions must be warranted for the warranty period of two years. A statement in such written instructions to the effect of "repair or replace as necessary" will not reduce the period of warranty coverage. Any such part repaired or replaced under warranty must be warranted for a time not less than the remaining warranty period.
 - C. Any warranted part that is scheduled for replacement as required maintenance in the written instructions must be warranted for the period of time prior to the first scheduled replacement point for that part. If the part fails prior to the first scheduled replacement, the part must be repaired or replaced by Exmark Manufacturing Company. Any such part repaired or replaced under warranty must be warranted for a time not less than the remainder of the period prior to the first scheduled replacement point for the part.
 - D. Repair or replacement of any warranted part under the warranty provisions of this article must be performed at no charge to the owner at an Authorized Service Dealer.
 - E. Notwithstanding the provisions of subsection (D) above, warranty services or repairs must be provided at an Authorized Service Dealer.
 - F. The owner must not be charged for diagnostic labor that leads to the determination that a warranted part is in fact defective, provided that such diagnostic work is performed at an Authorized Service Dealer.
 - G. Throughout the evaporative emission control system's two year warranty period, Exmark Manufacturing Company must maintain a supply of warranted parts sufficient to meet the expected demand for such parts.
 - H. Manufacturer approved replacement parts must be used in the performance of any warranty maintenance or repairs and must be provided without charge to the owner. Such use will not reduce the warranty obligations of Exmark Manufacturing Company.
 - I. The use of any add-on or modified parts will be grounds for disallowing a warranty claim made in accordance with this article. Exmark Manufacturing Company will not be liable under this Article to warrant failures of warranted parts caused by the use of an add-on or modified part.
 - J. Exmark Manufacturing Company shall provide any documents that describe the warranty procedures or policies within five working days of request by the Air Resources Board.

Emission Warranty Parts List:

The following list includes the parts covered under this warranty:

- Fuel Lines
- Fuel Line Fittings
- Clamps

NOTES

NOTES

NOTES

SEE EXMARK'S COMPLETE LINE OF ACCESSORIES

RIDING ACCESSORIES

CUSTOM RIDE SEAT SUSPENSION SYSTEM
DECK LIFT ASSIST KIT
HITCH KIT
LIGHT KIT
MICRO-MULCH SYSTEM
ROLL OVER PROTECTION SYSTEM (ROPS)
SNOW BLADE
SUN SHADE
TRASH CONTAINER
TURF STRIPER
ULTRA VAC COLLECTION SYSTEM
ULTRA VAC QUICK DISPOSAL SYSTEM

WALK BEHIND ACCESSORIES

GRASS CATCHER
MICRO-MULCH SYSTEM
STEERABLE SULKY
SULKY HITCH KIT
TURF STRIPER
STANDON

Check us out on the Web:

www.exmark.com



WARNING



The engine exhaust from this product contains chemicals known to the State of California to cause cancer, birth defects, or other reproductive harm.

© 2005-2006 EXMARK MFG. CO. INC.
INDUSTRIAL PARK BOX 808
BEATRICE, NE 68310

PART NO. 109-5511 Rev. A
(402) 223-6300
FAX (402) 223-5489

ALL RIGHTS RESERVED

PRINTED IN U.S.A.

